

Potenza Termica Nominale Nominal heating capacity of the Oven	Kcal/h = 22.000	Kw = 25,6
Temperatura di utilizzo Temperature of use	°C = 250 / 450	°F = 480 / 840
Diemetro canna fumaria Flue exit diameter	Ø mm = 200	Ø inch = 7,87
Temperatura dei fumi al raccordo Flue gas temperature at the manifold	°C = 195 / 220	°F = 380 - 430
Volume di evacuazione richiesto Flue extraction required	Nm3/h = 280 / 300	CFM [ft3/min] = 165 / 176,6
ΔP Canna fumaria (pressione differenziale) ΔP Chimney (chimney differential pressure)	mmH2O = - 0,4	Pa = - 3,93
Alimentazione elettrica Electric Power Supply	V= 220/240 - Hz= 50/60 - W= 300	-----
Pressione gas richiesta Required Gas Pressure	Ng- 20 mBar/ Lpg 30 mBar	-----
Potenza Gas Richiesta Required Gas Power	Kw 34	-----



REFRATTARI VALORIANI S.R.L.

Via Caselli alla Fornace 213 -
50066 Reggello (FI) Italia tel. +39-055868069

	NOME	FIRMA	DATA	MATERIALE:
DISEGNATO	Rapaccini A.			Vario
VERIFICATO				
APPROVATO				
QUALITA'				
				FINITURA:
				Painted
				PESO: Kg 1750

NON SCALARE IL DISEGNO

REVISIONE

TITOLO:

**Igloo 140 x 160
Gas**

N. DISEGNO

20221128/0

A3

SCALA:1:20

FOGLIO 1 DI 1

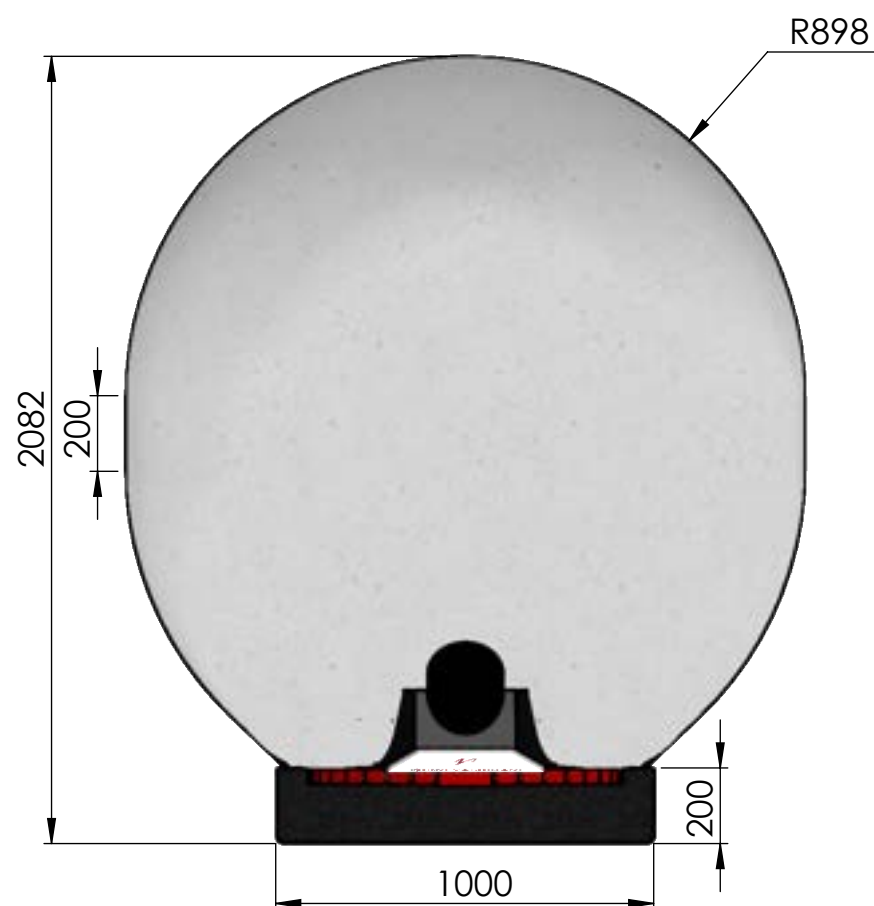
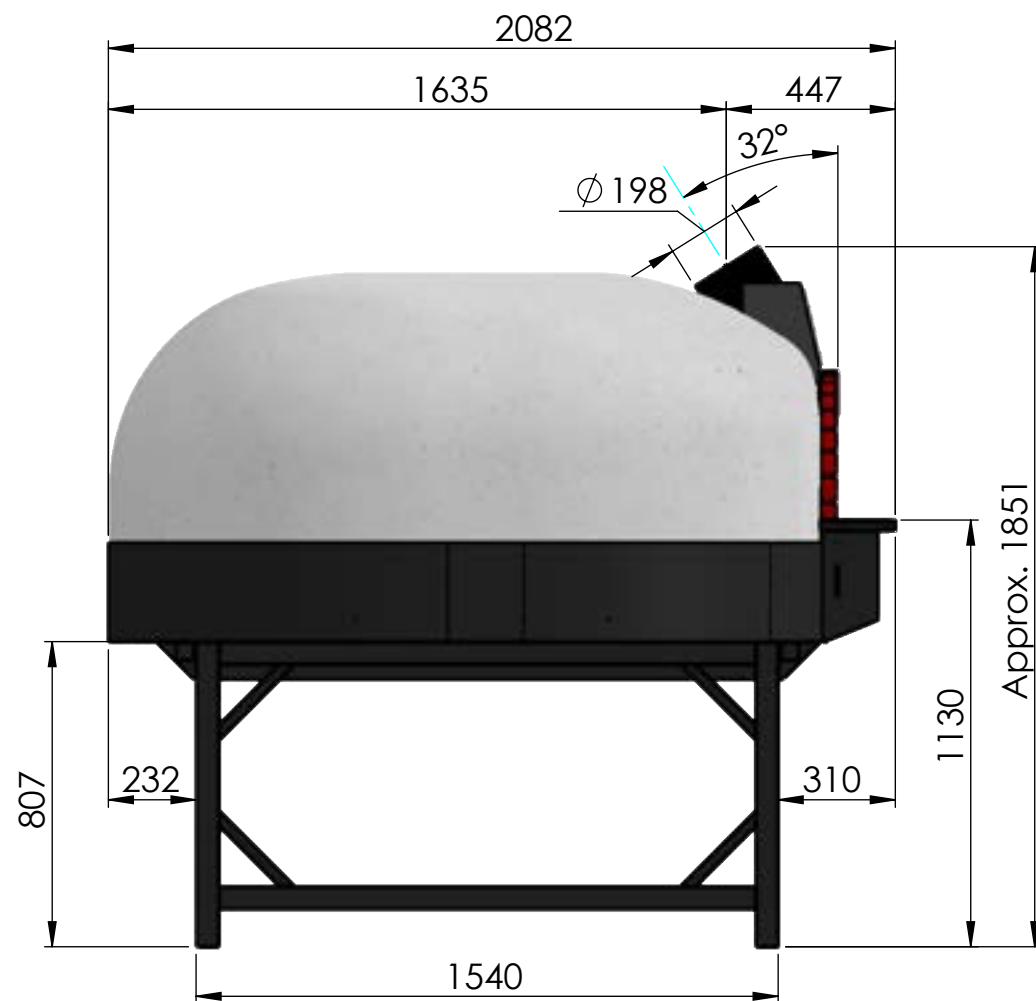
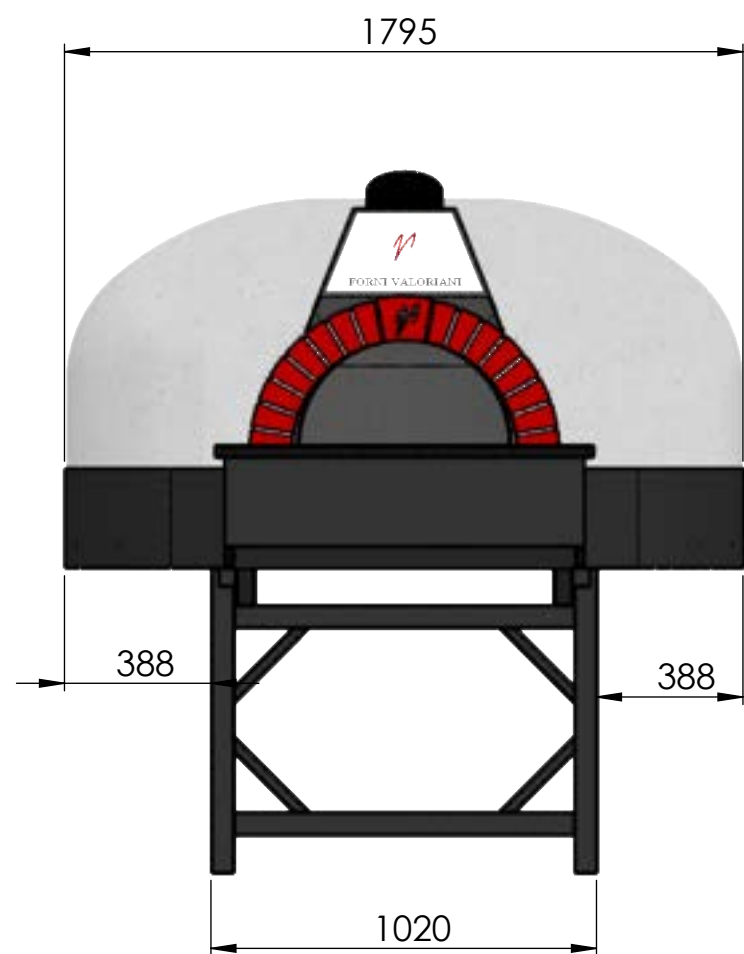

Potenza Termica Nominale Nominal heating capacity of the Oven	Kcal/h = 22.000	Kw = 25,6
Temperatura di utilizzo Temperature of use	°C = 250 / 450	°F = 480 / 840
Diemetro canna fumaria Flue exit diameter	Ø mm = 200	Ø inch = 7,87
Temperatura dei fumi al raccordo Flue gas temperature at the manifold	°C = 195 / 220	°F = 380 - 430
Volume di evacuazione richiesto Flue extraction required	Nm3/h = 280 / 300	CFM [ft3/min] = 165 / 176,6
ΔP Canna fumaria (pressione differenziale) ΔP Chimney (chimney differential pressure)	mmH2O = - 0,4	Pa = - 3,93
Alimentazione elettrica Electric Power Supply	N.A.	-----
Pressione gas richiesta Required Gas Pressure	N.A.	-----
Potenza Gas Richiesta Required Gas Power	N.A.	-----



REFRATTARI VALORIANI S.R.L.

Via Caselli alla Fornace 213 -
50066 Reggello (FI) Italia tel. +39-055868069

	NOME	FIRMA	DATA	MATERIALE:
DISEGNATO	Rapaccini A.			Vario
VERIFICATO				
APPROVATO				
QUALITA'				
				FINITURA:
				Painted
				PESO: Kg 1750

NON SCALARE IL DISEGNO

REVISIONE

TITOLO:

**Igloo 140 X 160
Legna**

N. DISEGNO

20221125/0

A3

SCALA:1:20

FOGLIO 1 DI 1